

General Description

Max Power¹ 22,7 kW (28,4 kVA)	Prime Power² 20,7 kW (26 kVA)	Voltage 230 V / 115 V 115 V
Frecuence 50 Hz	Current intensity 124 Amps. 4,99 Amps.	Fase 2 phas.

Dimensions and Weights

	Length	Width	Height	Weights
With canopy	1670 mm (65,75 in)	740 mm (29,13 in)	837 mm (32,95 in)	610 Kg (1344 Lbs)
Without canopy	1507 mm (59,31 in)	740 mm (29,13 in)	781 mm (30,76 in)	570 Kg (1257 Lbs)

Engine

Engine base	Mitsubishi	Bore	94 mm (3,7 in)
Solé Diesel engine model	MINI - 44	Stroke	120 mm (4,72 in)
Type	4 Type	Compression ratio	22:1
RPM Engine	1500	Combustion system	Indirect mechanical injection
Number of cylinders	4	Aspiration	Naturally aspirated
Displacement	3331 cc	Flywheel housing size	SAE 3
Oil type	SAE 15W40	Coolant capacity	13 L (3,43 Gal)
Oil capacity	9 L (2,38 Gal)	Flywheel size	SAE 11 1/2
Output power	30,8 kW (41,3 HP)	Coolant flow rate	0,72 L/Min.(0,19 Gal/Min.)
Raw water flow rate	2,25 L/Min.(0,59 Gal/Min.)	Engine combustion air requirements	2,25 m ³ /min
Refrigeración de aire	6,3 m ³ /min.		

Rating conditions according to ISO 3046 (100 kPa barometric pressure, 30 % relative humidity and 25 °C (77° F))
 Full load at 7 meters

* 1 Maximum Output Power: maximum power supplied by the genset at full load.

* 2 Prime Power: Rated Power according to ISO 3046 and ISO 8528-1. 10 % overload capacity one hour in twelve hours.

Fuel system

Typical Fuel Consumption

25 %	2,9 L/Hs. (0,77 Gal/Hs.)
50 %	4,3 L/Hs. (1,14 Gal/Hs.)
75 %	6,1 L/Hs. (1,61 Gal/Hs.)
100 %	8,2 L/Hs. (2,17 Gal/Hs.)

Tipo de Combustible	Diesel
Calidad de Combustible	Diesel ASTM
Type of Injection Pump	In line
Pump Regulator Type	Centrifugal

Engine electrical

Battery voltage	12 V	Fuel shutoff solenoid	ETR
Starter motor	2,2 kW	Alternator	50 A

Installation details

Ø int. Exhaust Hose (mm)	76 mm (2,99 in)	Maximum recommended fuel lift	0,6 m (1,97 ft)
Ø int. Raw Water Hose (mm)	32 mm (1,26 in)	Maximum recommended raw water lift	2,5 m (98,43 in)
Ø int. Fuel supply hose (mm)	8 mm (0,31 in)	Raw water maximum temperature	32 ° C (89,6 ° F)
Ø int. Fuel return hose (mm)	0 mm (0 in)	Maximun instalation angle (°)***	15 °
Min. Battery capacity (Ah)	12 V 92 Amps/h		

Alternator Details

Brand	Meccalte	Cos φ	0,8
Model	SK160MA	Tropicalización	Standard
Regulator type	DSR	Excitation system	Brushless
# of poles	4	Voltage regulation Accuracy**	±1%
Insulation Type*	H	Standards	EN60034-1, IEC 60034-1
IP protection*	23	Frequency Regulation	Synchronous

Optional Equipment

- Siphon break kit - mandatory if generator is below waterline
- Engine electrical system at 24V
- Service/Cruise Kits: fuel and oil filters, raw water pump, impeller, alternator belt,...
- Dry Exhaust system
- Earth isolated system
- Exhaust System
- Water Filters
- Welcome Kit
- Keel Cooling conversion for dry and wet exhaust
- Double walled pipes and alarm kit
- Low coolant level shut down switch
- Fuel filter/water separator
- Gas/Water Separator
- Fuel Hose
- Exhaust Hose
- Raw water hose
- Sea cök

For other requirements please contact the Sales Dept.

* Other protections available

** With load from 0 to 100%, speed variation from -2% up to +5%, power factor 0,8 linear and balanced load.

*** In all directions



Welcome Kit



General Description

- Graphic LCD with light, 128 x 64 pixels display
- 44 LED indicators
- Genset Measures (see Display Information)
- Configuration protected by password
- Running hour indication
- Multilanguage
- Genset protections (see Alarm Management)
- Preheating function
- D+ pre-excitation Terminal
- CAN bus information output with SAE J1939 protocol
- Dos temporizadores multiuso
- Dimensions 180 x 120 x 55 mm
- Weight 450g

Alarm Management

Shut Downs (SD)

- High coolant temperature
- Low oil pressure
- Overspeed
- Overload*
- Short circuit*
- Overcurrent*
- Over/Under voltage
- Over/Under frequency
- Emergency stop

Warnings (WRN)

- High coolant temperature
- Low oil pressure
- Over/Under voltage
- Maintenance request

Sensor Fails (FLS)

Function Description

- OFF Mode
- MAN Mode (manual start/stop engine)
- AUT Mode (auto start/stop engine)



Kit Armario IP 65

*The specified function needs the current transformers (Optional Equipment) for showing the information in SCO 10 panel display

Power Supply

- Voltage supply 12/24V DC with fuse protection
- Consumption 80/51mA

Operating Conditions

- Operating temperature -20+70°C
- Humidity 95% Without condensation
- Front Panel Protection IP108

Standard Conformity

- Low Voltage Directive EN 61010-1:95 +A1:139 EN 61010-1:95 +A1:97
- Electromagnetic EN 50081-1:94, EN 50081-2:138 EN 50081-1:94, EN 50081-2:96
- Compatibility EN 50082-1:99, EN 50082-2:139 EN 50082-1:99, EN 50082-2:97

Display Information

Measurement

- L1-L3 Voltage (V), Frequency (Hz), Oil Pressure, (bar), Coolant Temperature (°C), Battery, Voltage (V), rpm, Active Power* (kW), Apparent, Voltage (V), rpm, Active Power* (kW), Apparent, Power* (kVA), Current* (A), PF*.

History log

Optional Equipment

SCO 10 Double panel

- SCO 10 Double panel allows the same operation and functionality as Main SCO 10. They are connected by RS485 port with a communication wire, available in 12/24/36 m.

Kit Armario IP 65

- Electrical Box for SCO 10 panel with an IP65 protection code. In addition, it includes an emergency stop button and an on/off panel power switch.

Binary Input/Output extension module

IG-IB Internet communication bridge

- For Ethernet/Internet communications

Current transformers

- Current (A), Active Power (kW), Apparent power (kVA) and PF genset measures

Dimensions

29 GS/GSC - 32 GSA/GSAC

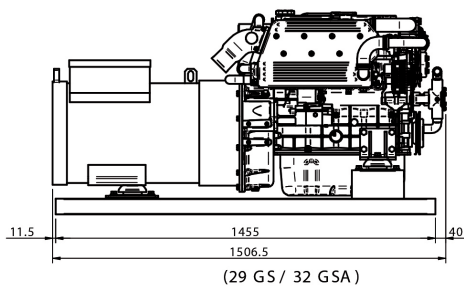

SIPHON BREAK CONNECTIONS
(AIR VENT SYSTEM - OPTIONAL KIT)

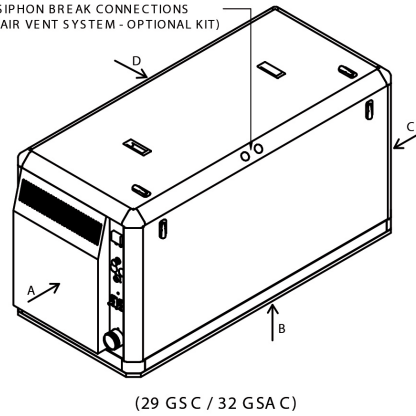

VIE W A

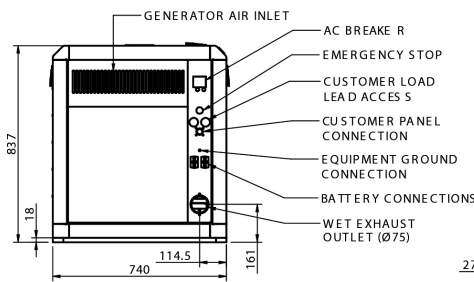

VIE W D

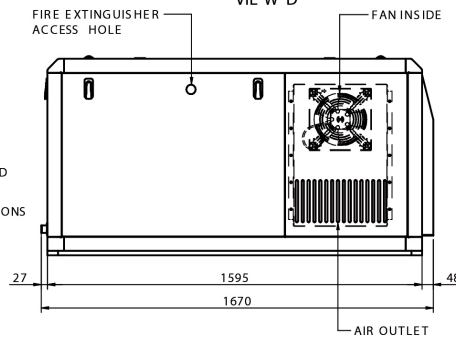

VIE W C

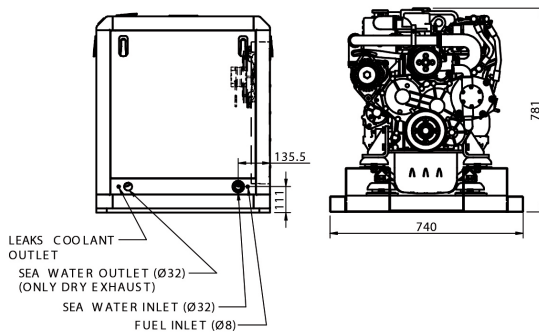

VIE W B

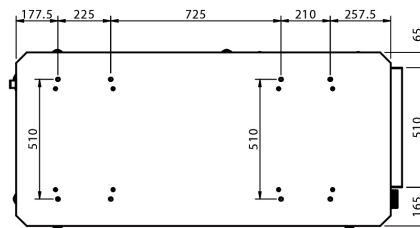

Dimensions in millimetres
This drawing is provided for reference only.