



MARINE GENERATOR SET

25 GT/GTC 24,3 kVA (19,5 kW) 50 Hz

30 GTA/GTAC 30 kVA (24 kW) 60 Hz

3 - Phase



Features and Benefits

Solé Diesel Gensets offer compactness, extremely low noise and vibration levels coupled with a high level of build quality.

The aluminium canopy provides the best power to weight ratio possible whilst giving the optimum user friendly operating characteristics possible.

The latest COMAP digital panel that incorporates the CAN system. This protocol, simplifies and economizes the communication between terminals.

All Solé products comply with the latest European Emission Levels and additional certification such as CE, RRR, RMRS, EPA Tier II and BV is available on request.

Solé Diesels now has a market presence in over 50 countries worldwide, which gives a comprehensive after sales service when ever and where ever needed.

The close relationship with global engine suppliers such as Deutz and Mitsubishi ensures that extra level of reliability and support.

Models and Ratings

Model	kW	kVA	Voltage	Amps	Phase	Hz	Engine RPM
25 GT/GTC	19,5	24,3	400/230	28,2	3	50	1500
			230	49,0	3	50	1500
30 GTA/GTAC	24	30	480/277	28,9	3	60	1800
			277	50,1	3	60	1800

Sound Level, Size and Weight

	Sound level (dB) ¹		Dimensions (mm)			Weight (Dry) (kg)
	50 Hz	60 Hz	Lenght	Width	Height	
With Canopy	56	58	1310	610	698	412
Without Canopy			1139	610	662	

¹ Full Load at 7 meters

Ratings: Marine ratings per ISO 3046 (100 kPa barometric pressure, 30% relativity and 25 °C temperature)

² Not Available. Please contact the Sales Dept.





MARINE GENERATOR SET

- Engine

Engine Specifications

Base	MITSUBISHI	
Solé Engine Model	MINI-63	
Type	4 stroke	
Cylinder	4	
Displacement	2.505 cc	
Bore and Stroke	88x103 mm	
Compression ratio	22:1	
Injection	Indirect	
Aspiration type	Naturally aspirated	
Lube Oil capacity (L)	6,5	
Oil Type	ACEA E5, API CH-4/SJ, 15W40	
Coolant capacity (L)	9,5	
Housing	SAE 5	
Flywheel	SAE 8	
	50 Hz	60 Hz
RPM	1.500	1.800
Power (Hp / kW)	29.8 / 22.2	36.5 / 27.2
Coolant flow rate (L/min)	51	63
Raw water flow (L/min)	37,5	45
Engine/generator Air cooling requirements (m3/min)	4,6	5,6

Typical fuel Consumption

	50 Hz	60 Hz
25%	2,5	3,1
50%	3,6	4,4
75%	5,0	6,0
100%	6,6	8,0

Diesel Liters/h at % load

- Alternator

Alternator Details

Brand	SINCRO
Model	SK 160LA
Regulator type:	AVR BL4 electronic
# of poles	4
Insulation Type*	H
IP protection*	23
Cos phi	0,8
Tropicalización	Standard
Excitation system	Brushless
Voltage regulation Accuracy**	± 1%
Standars	EN 60034-1, IEC 60034-1, ISO 8528-3
Frequency Regulation	Synchronous

* Other protections available · ** With load from 0 to 100%, speed variation from -2% up to +5%, power factor 0,8 linear and balanced load. *** In all directions

Engine Electrical

Electrical System (V)	12
Starter Motor (kW)	2
Alternator (A)	50
Shutdown system	Electrical
Stop Solenoid Type	ETR

Installation Details (Without Canopy)

Ø int. Exhaust Hose (mm)	60
Ø int. Raw Water Hose (mm)	32
Ø int. Fuel supply hose (mm)	8
Ø int. Fuel return hose (mm)	6,5
Max. Fuel lift (m)	1
Max. Raw water lift (m)	2,5
Max. Raw water temperature (°C)	35
Maximun instalation angle (°)***	15
Min. Battery capacity (Ah)	12V / 90 Ah

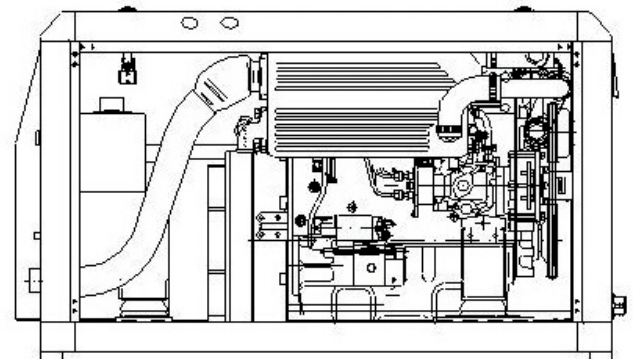



MARINE GENERATOR SET



Control Panel SCO 10

General Description

- Graphic LCD with light, 128 x 64 pixels display
- 2 LED indicators
- Genset Measures (see Display Information)
- Configuration protected by password
- Running hour indication
- Multilanguage
- Genset protections (see Alarm Management)
- Preheating function
- D+ pre-excitation Terminal
- CAN bus information output with SAE J1939 protocol
- Two multipurpose timers

Power Supply

- Voltage supply 12/24V DC with fuse protection
- Consumption 80/51mA

Operating Conditions

- Operating temperature -20+70°C
- Humidity 95% Without condensation
- Protection front panel IP65
- Standard Conformity
 - Low Voltage Directive EN 61010-1:95 +A1:97
 - Electromagnetic EN 50081-1:94, EN 50081-2:96
 - Compatibility EN 50082-1:99, EN 50082-2:97

Function Description

- OFF Mode
- MAN Mode (manual start/stop engine)
- AUT Mode (auto start/stop engine)

Optional Equipment

- SCO 10 Double panel
SCO 10 Double panel allows the same operation and functionality as Main SCO 10. They are connected by RS485 port with a communication wire, available in 12/24/36 m.
- Current transformers
Current (A), Active Power (kW), Apparent power (kVA) and PF genset measures

Genset Accesories



Service/cruise kit

- Siphon break kit - mandatory if generator is below waterline
- Engine electrical system at 24V
- Service/Cruise Kits: fuel and oil filters, raw water pump impeller, alternator belt,...
- Dry Exhaust system
- Earth isolated system
- Exhaust System
- Keel Cooling conversion for dry and wet exhaust
- Double walled pipes and alarm kit
- Low coolant level shut down switch
- Fuel filter/water separator
- Gas/Water Separator
- Fuel Hose
- Exhaust Hose
- Raw water hose
- Water Filters
- Sea cök

For other requirements please contact the Sales Dept.

Solé Diesel Digital Display - SCO 10

- Dimensions 180 x 120 x 55 mm
- Weight 450g

Display Information

Measurement

L1-L3 Voltage (V), Frequency (Hz), Oil Pressure (bar), Coolant Temperature (°C), Battery Voltage (V), rpm, Active Power* (kW), Apparent Power* (kVA), Current* (A), PF*.

History log

Alarm Management

Shut Downs (SD)

- High coolant temperature
- Low oil pressure
- Overspeed
- Overload*
- Short circuit*
- Overcurrent*
- Over/Under voltage
- Over/Under frequency
- Emergency stop

Warnings (WRN)

- High coolant temperature
- Low oil pressure
- High/Low battery voltage
- Maintenance request

Sensor Fails (FLS)

Isolated transformers

Voltage transformer unit to separate mains voltage and controller with voltage ratio 1:1.

Binary Input/Output extension module

IG-IB Internet communication bridge

For Ethernet/Internet communications

* The specified function needs the current transformers (Optional Equipment) for showing the information in SCO 10 panel display





Dimensions

25 GT/GTC - 30 GTA/GTAC

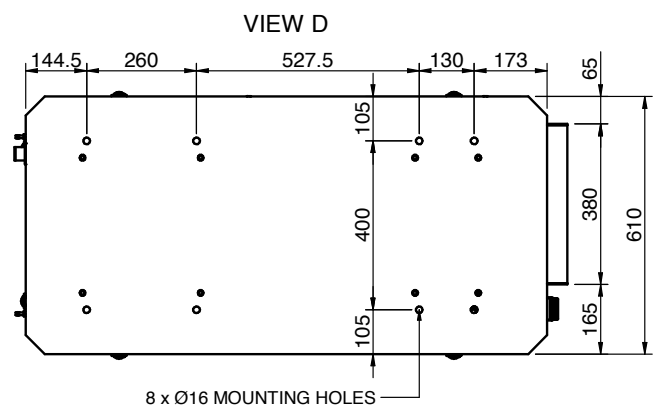
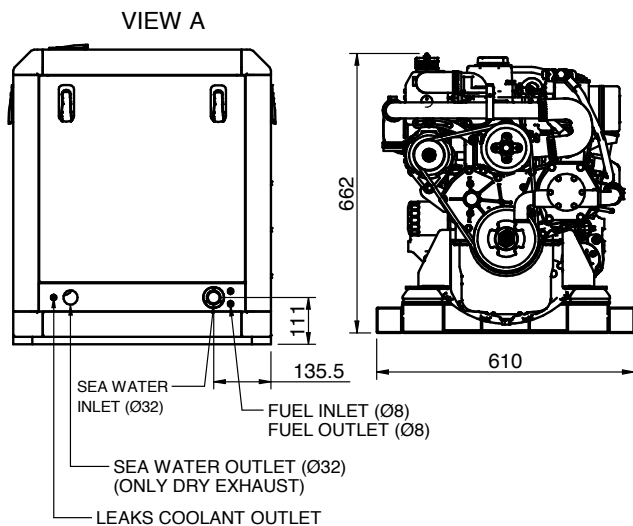
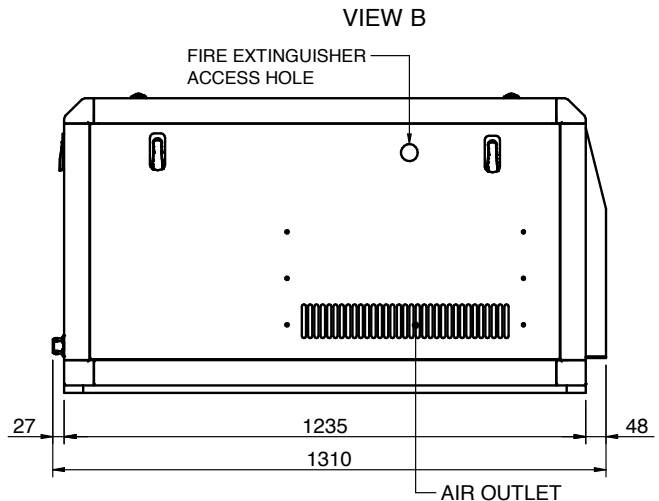
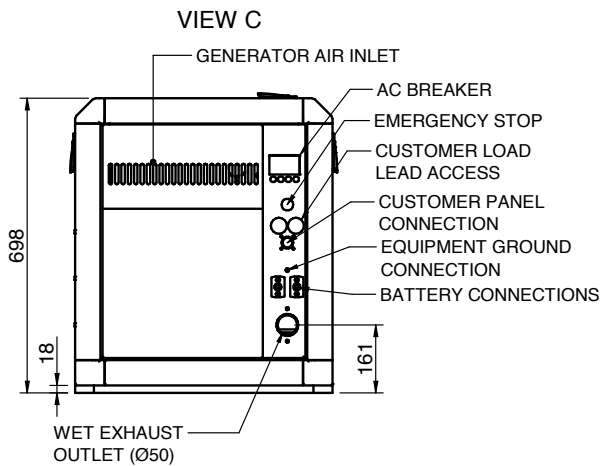
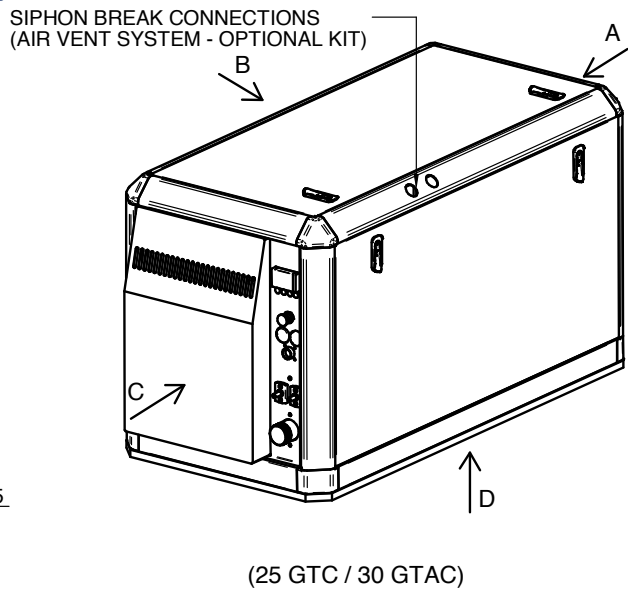
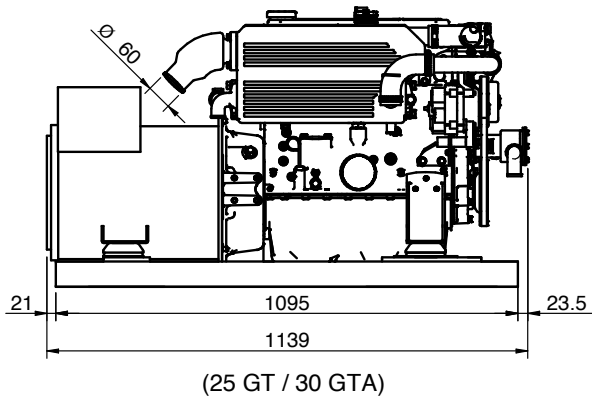

Dimensions in millimetres

This drawing is provided for reference only.

Distributed by:



SOLÉ, S.A. C-243 b, km 2. 08760 Martorell, Barcelona
Office Tel +34 93 775 14 00 - Fax +34 93 775 30 13

solediesel.com - info@solediesel.com

Detailed drawings, leaflets and manuals are available at solediesel.com. © 2015, Solé Diesel. All rights reserved. Texts and specifications are subject to change without notice and without any obligation or liability whatsoever.

