

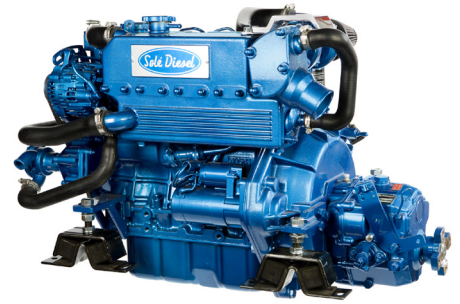

MINI-55

Inboard Engine Base Mitsubishi

4 cylinders in line 50 HP (36.8 kW) 3000 rpm



Technical Specifications

Base	Mitsubishi
Type	Diesel 4 Stroke Cycle
Number of Cylinders	4 in line
Intake System	Turbocharger
Bore x Stroke	78 mm x 92 mm (3,07 in x 3,62 in)
Total Displacement	1758 cc
Compression Ratio	22:1
Intermittent Power (ISO3046/1)	50 HP (36.8 kW)
Continuous Power	45 HP (33.1 kW)
Rated RPM	3000
Combustion System	Indirect mechanical injection
Starter Motor	12 V (1,7 kW)
Alternator	95 A 12 V
Engine Max Installation Angle	Max static angle 12° (+ 3° in operation)
Direction of Rotation (Crankshaft)	Anti Clockwise
Cooling System	Sea water cooled heat exchanger
Dry Weight (bobtail)	187 Kg (412 Lbs)
Water Hose (Inside Diameter)	28 mm (1,1 in)
Fuel Feed Hose (Inside Diameter)	8 mm (0,31 in)
Fuel Return Hose (Inside Diameter)	5 mm (0,2 in)
Exhaust hose (inside Diameter)	60 mm (2,36 in)
Certifications	EU: RCD II (Directive 2013/53/EU)

Dimensions

MINI-55 TMC-60

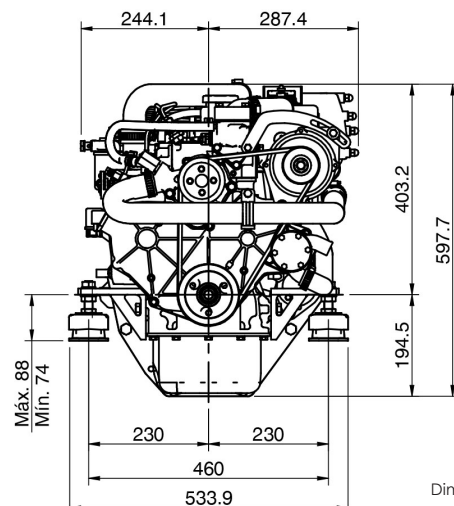
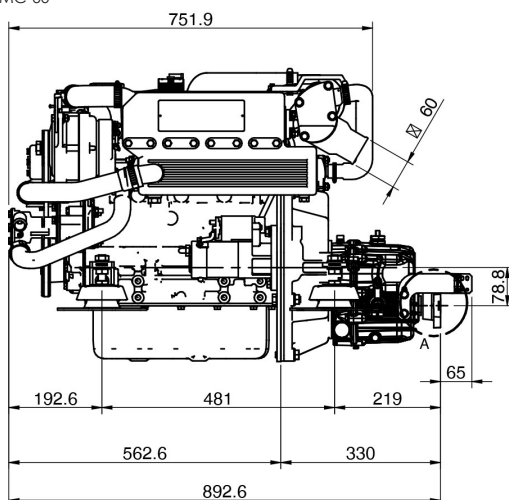

Dimensions in mm



Performance Curves

Crankshaft torque

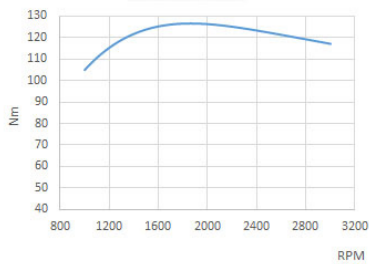

Power (ISO 3046/1)

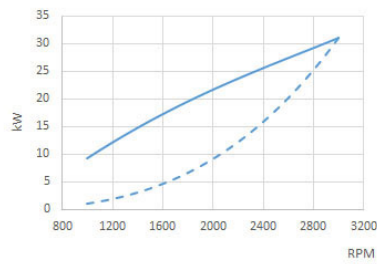

Fuel Consumption

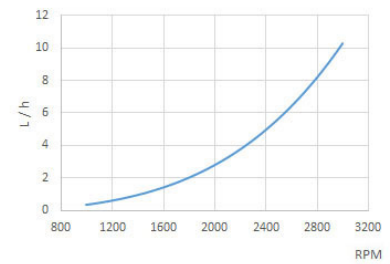

— Engine Power - - - Propeller Power

Panels

SVT 20 Standard



- Tachometer including hour meter
- Coolant Temperature Gauge
- Pre-heating Pilot Light
- Low Battery Alarm
- High Temperature Alarm
- Low Oil Pressure Alarm
- 5 Positions Key
- Dimensions: 205 x 155 mm



SVT 30 Optional

- Tachometer including hour meter
- Coolant Temperature Gauge
- Pre-heating Pilot Light
- Low Battery Alarm
- High Temperature Alarm
- Low Oil Pressure Alarm
- 5 Positions Key
- Oil Pressure Gauge
- Voltmeter
- Dimensions: 255 x 160 mm

Accessories

Scope of Supply

- Packaging
- Instrument Panel SVT 20
- Extension Harness 3 m
- Anti Vibration Mounts
- Sump Drain pump
- Owner's Manual

Optional Equipment & Kits

- Alternative gearboxes to suit your requirements
- Higher output or additional alternators
- Front mounted Power Take off and pulleys
- Engine feet at 390mm, 410mm or 440mm wide
- Special Engine Feet to suit existing installation
- Engine Installation kits and accessories

Gearbox

Model	Type	Down Angle	Reduction Ratio (Light Duty)	Reduction Ratio (Cont. Duty)	Engine Weight with Gearbox
SP60	Sail Drive	0°	2.14:1	-	225 Kg (496 Lbs)
TM-345	Hydraulic	0°	2.00:1 - 1.54:1 - 2.47:1	2.00:1 - 1.54:1 - 2.47:1	207 Kg (456 Lbs)
TM-345A	Hydraulic	8°	2.47:1 - 2.00:1	2.47:1 - 2.00:1	207 Kg (456 Lbs)
TM-93	Hydraulic	0°	2.09:1 - 2.77:1 - 2.40:1	2.09:1 - 2.77:1 - 2.40:1	244 Kg (538 Lbs)
TMC-260	Mechanical	0°	2.47:1 - 2.00:1	2.47:1 - 2.00:1	207 Kg (456 Lbs)
TMC-60A	Mechanical	7°	2:1 - 2.45:1	-	192 Kg (423 Lbs)
TMC-60P	Mechanical	0°	2.45:1 - 2:1 - 1.55:1	1.55:1	192 Kg (423 Lbs)
ZF 15 MIV	V-Drive M.	15°	2.134:1	-	199 Kg (439 Lbs)

Authorised Distributor



Engines Plus Ltd
Tel – 01452 729707
E-mail – sales@enginesplus.co.uk
Website – www.sole-diesel.co.uk



solediesel.com - sales@enginesplus.co.uk

Detailed drawings, brochures and manuals are available on the web. © 2017, Solé Diesel. All rights reserved. Technical specifications, data and presentation are subjected to variations, changes and updates without prior notice, and without any obligation or liability whatsoever. Text and illustrations are not binding.

